

# Safety Relief Valve

THE GAS INDUSTRY



**SENSUS**

## Purpose

Safe practice in the transmission, distribution and utilization of gas requires a device to limit line pressure to a predetermined safe maximum to prevent over pressuring the system. Mechanical failure, accidents or foreign matter in the lines may render other types of safeguards inoperative and cause a dangerous over pressuring of the system.

Leaking bypass valves occasionally will permit pressure to build during off-peak hours. Pressure regulators with damaged valves or seats are not able to effectively shutoff when required, thereby permitting a possibly dangerous overpressure condition.

The surest safeguard is a device which will open as necessary and discharge to atmosphere enough of the excess to maintain a safe pressure in the system.

The most positive and commonly used device is a mechanical relief valve, correctly installed at a safe dispersal point and set to discharge to atmosphere when line pressure exceeds a predetermined set point. Easy to install, the relief valve offers an economical installation with large relieving capacity. It automatically closes when the pressure returns to normal. Many times a small relief valve can be used advantageously with a larger relief valve. The smaller relief valve can be set for a lower discharge pressure to take care of minor pressure fluctuations without the necessity of venting a large amount of gas to atmosphere through the larger relief valve.

## Operation

The operation of Sensus Relief Valves is positive and simple. They are normally installed in a vertical line with the outlet usually connected to a rigid discharge stack with a suitable protective cap. A soft-seated valve is exposed to line pressure and under normal conditions is held tightly closed by the force exerted by weights of a spring. When line pressure increases sufficiently to overcome the closing force, the relief valve opens to discharge gas. The relief valve automatically closes after pressure returns to normal.

## Contents

Selection of Size – How to Order **3**

Capacities at Other Pressures –  
Periodic Inspection – Temperature Limits  
Buried Service – Metrication – Other Gases **4**

Model 257-S Safety Relief Valve **5 – 7**

Model 250 Safety Relief Valves **8**

Model 250-DW Deadweight Loaded **9**

Model 250-S Spring Loaded **10**

Other Sensus Metering Systems  
Gas Pressure Regulators **11**

## Selection of Type

The relief pressure and capacity requirements will largely dictate the relief valve type to use. Where relief ranges and capacities may overlap, the maximum blowing pressure, ease of adjustment, protection against tampering, and price may dictate the selection. For example, the 257S requires a pressure buildup to achieve maximum capacity (as noted in the Relief Valve Set-Point Section of Sensus Bulletin RDS-1452). The 250 Relief Valves offer capacity and pressure buildups (as noted on pages 9 and 10 of this bulletin) and interchangeability of parts between spring and deadweight models.

These are some of the considerations you should make when selecting the type of relief valve best suited for your application.

## Selection of Size

Several factors must be considered in sizing a relief valve.

### 1. Initial Relief Pressure

(Pc) when the valve first permits flow. To conserve gas, it should be higher than normal operating pressures. For distribution use, it is usually 12 to 16 ounces. At higher operating pressures, the gap between normal and initial relief pressure can be greater.

### 2. Maximum Blowing Pressure

(Pm) the highest permissible pressure to which the line pressure may increase, which largely determines valve capacity. After initial opening, a further increase in pressure is required for full valve travel.

### 3. Discharge Capacity of Relief Valve

at maximum blowing pressure. See capacity tables, which give discharge in CFH of standard gas. When the allowable increase is a greater percentage than shown in the capacity table, use the flow capacity shown for the actual maximum blowing pressure.

### 4. Relief Volume Required

must be determined from system layout, inlet pressures, regulator capacities, minimum load and other operating conditions. A relief valve, operating at a low differential, obviously would be unable to discharge the total flow of an equal size regulator operating at a high differential, if the regulator failed wide open. In this connection it is important to analyze the operating characteristics of the regulator used.

In some regulators, diaphragm failure will not result in wide open flow; nor can a valve drop wide open.

It is also very important that pressure regulators be correctly sized to suit load conditions. In this way, relief volume requirements can be greatly reduced.

In some situations the safety valve may be required to relieve only the leakage through faulty regulator valves in the closed position or leaking bypass valves. In this instance the capacity of a safety valve of the same nominal pipe size as the outlet line would be adequate.

Where full capacity relief is required, the capacity of the regulator must be determined using the maximum expected inlet pressure. That volume would be the required discharge capacity of the safety valve less any minimum load, assuming the regulator failed wide open.



Safety Relief Valves

## How to Order

### Specify

1. Model Number and Size
2. Connections
3. Initial Relief Pressure (Pc)
4. Maximum Blowing Pressure (Pm)
5. Discharge Capacity (SCFH)
6. Type of Gas (natural, propane, etc.)

## Maximum Emergency Pressures

The maximum pressure the relief valve inlet may be subjected to under abnormal conditions without causing damage to the internal parts of the relief valve is set point plus buildup (Maximum Blowing Pressure) found at the Relief Valve Set-Point Section of Sensus Metering Systems Bulletin RDS-1452.

Set-point is defined as the relief pressure at which the relief valve is adjusted to open.

If the above pressure limit is exceeded, the relief valve must be taken out of service and inspected. Damaged or otherwise unsatisfactory parts must be repaired or replaced.

The maximum pressure that can be safely contained by the diaphragm case of all relief valves: – 175 psi.

Safely contained means no leakage as well as no bursting.

### CAUTION:

Before using any of the above data, make sure this entire section is clearly understood.

The relief valve is very often the final protection for the downstream system and it is therefore very important that the worst failure condition be considered for proper sizing of the relief valve.

## Capacities at Other Pressures

Capacity for pressure reductions not listed in the table can be calculated with the following formulae:

$$1. Q = K \sqrt{P_0(P_1 - P_0)}$$

$$2. Q = \frac{KP_1}{2}$$

Q = maximum capacity of the regulator (in SCFH of 0.6 specific gravity natural gas)

K = the "K" factor, the regulator constant (from bottom of table on Page 7)

P<sub>1</sub> = **absolute** inlet pressure (psia)

P<sub>2</sub> = **absolute** outlet pressure (psia)

Use formula 1 when  $\frac{P_1}{P_0}$  is less than 1.894

Use formula 2 when  $\frac{P_1}{P_0}$  is greater than 1.894

## Periodic Inspection

Relief valves are pressure control devices with moving parts subject to wear that is dependent upon particular operating conditions. To assure continuous satisfactory operation, a periodic inspection schedule must be adhered to with the frequency of inspection determined by the severity of service and applicable laws and regulations.

### Temperature Limits

Relief valves may be used for flowing gas temperatures from -20°F to 150°F.

### Metrication

Use the following for metric conversions:

std. meters<sup>3</sup>/hr. x 35.31 = std. ft.<sup>3</sup>/hr. (SCFH)

std. ft.<sup>3</sup>/hr.(SCFH) x 0.0283 = std. meters<sup>3</sup>/hr.

kilograms/centimeter<sup>2</sup> (kg/cm<sup>2</sup>) x 14.22 = psig  
psig x 0.0703 = kilograms/centimeter<sup>2</sup> (kg/cm<sup>2</sup>)

kilopascals (kPa) x 0.145 = psig  
psig x 6.90 = kilopascals (kPa)

bars x 14.50 = psig  
psig x .069 = bars

millimeters water (mm H<sub>2</sub>O) x .0394 = in. w.c.  
in. w.c. x 25.4 = millimeters water (mm H<sub>2</sub>O)

millimeters mercury (mm Hg) x 0.535 = in. w.c.  
in. w.c. x 1.868 = millimeters mercury (mm Hg)

### Buried Service

Relief valves are not recommended for buried service.

### Other Gas

Relief valves are mainly used on natural gas. However, they perform equally well on LP gas, nitrogen, dry CO<sub>2</sub>, air and others.

Other Gases	Correction Factor
<b>Air</b> (Specific Gravity 1.0)	0.77
<b>Propane</b> (Specific Gravity 1.53)	0.63
<b>1350 BTU Propane-Air Mix</b> (Specific Gravity 1.20)	0.71
<b>Nitrogen</b> (Specific Gravity 0.97)	0.79
<b>Dry Carbon Dioxide</b> (Specific Gravity 1.52)	0.63

For other non-corrosive gases:  
**Correction Factor** =  $\sqrt{\frac{0.6}{\text{Specific Gravity of the Gas}}}$

# Model 257S Safety Relief Valve



Safety Relief Valves

### Large Capacity for

- Gas Distribution Systems
- Metering Sets
- Industrial Applications

### Horizontal or Vertical Piping

- Install as shown in horizontal pipe or sideways in vertical pipe.
- Note: Horizontal mounting is recommended.

### Heavy Duty Iron Construction

- Weatherproof
- Watertight
- Indoors or Outdoors

### Patented Roll-Out Diaphragm

- Maximum relief with minimum pressure build up.
- Accurate repeatability

### Patented Ball-Check Diaphragm Sentry

### Test Plug on Inlet

### Drain Plug on Outlet

- for vertical piping

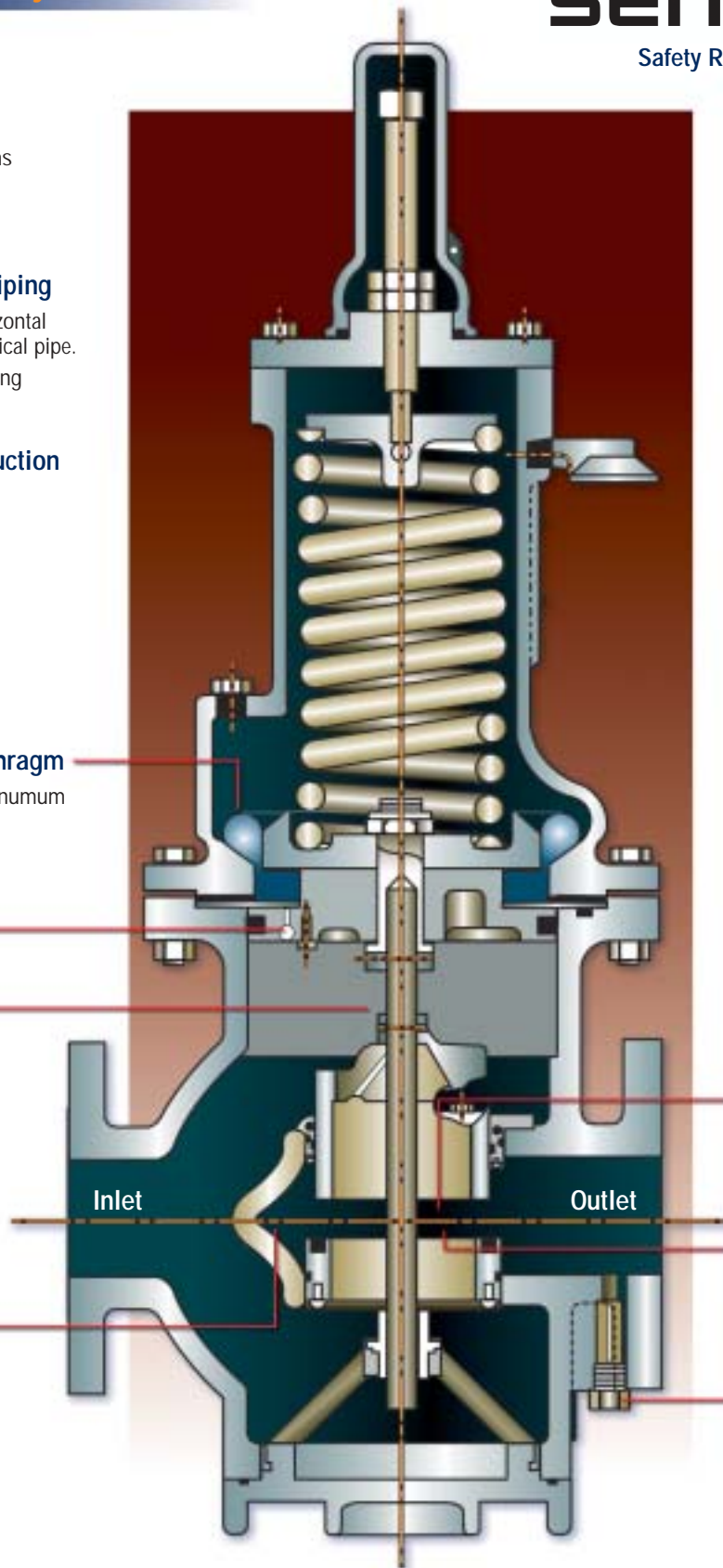

### Materials of Construction

- Body, Diaphragm Case Spring Housing Cast Iron (ASTM A 126 Class B)
- Housing Cover (Spring Cage Cap) Steel
- Upper Diaphragm Plate Aluminum
- Diaphragm Buna-N with Dacron Reinforcement
- O-Ring Piston Cast Iron
- Diaphragm Stud Steel
- Valve Stem Stainless Steel
- Stem Bushing Stainless Steel
- Valve Sleeve Aluminum (Teflon Coated)
- Valve Sleeve Guide Steel with Low Friction Insert
- Valve Steel
- Valve Soft Seat Poly-U

### Poly-U Molded Soft Seat

- Tight seat and reset

### Patented Double-Port Single Seat Valve

- Large capacity

### Drain Plug on Outlet

- for horizontal piping

Pipe Sizes 2" – 3" – 4"

Pressure Relief Range

Flanged ANSI 125 lb. FF

(Maximum working pressure 175 psi)

2 to 100 psi

## “Roll-Out” Diaphragm

The 257S is a unique safety relief valve. It features the same “Roll-Out” Diaphragm principle that has achieved such remarkable success in the widely used 441-57S and 461-57S Regulators.

The “Roll-Out” Diaphragm is a combination of strength and flexibility in which diaphragm action is constantly matched with spring action. The result is a major advance in relief valve performance.

It takes a pressure buildup to open the 257S wide for maximum relief capacity. Conventional spring type relief valves require large increases in pressure to open wide – whereas the “Roll-Out” Diaphragm fully opens the 257S with only a small increase above the set-point, as shown in the Relief Valve Set-Point Section of Sensus Metering Systems Bulletin RDS-1452.

In addition it closes with minimum “blow down” when pressure returns to normal. And, repeatability is excellent. The 257S is versatile – use it for any relief pressure between 2 and 100 psi.

**Double Port – Single Seat** ...a unique design that offers:

- Large Capacity
- Tight Seat and Reseat
- Easy Servicing
- Sturdy Construction
- No Adjustments

The drawings below, show how this relief valve works.

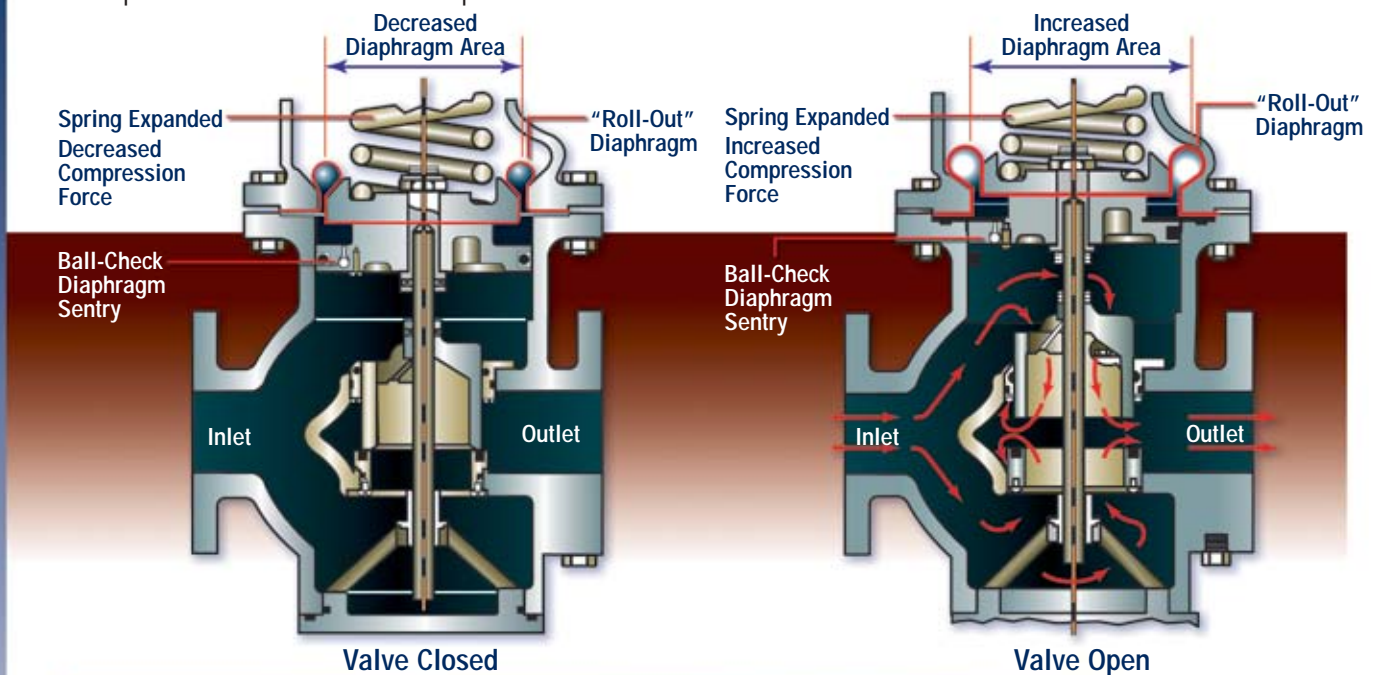

## Ball-Check Diaphragm Sentry

This feature maintains relief protection if something should cause a failure in the diaphragm.

Sentry operation is illustrated by the two small sketches above. Normally, the ball is open for unobstructed passage of pressure to the “Roll-Out” Diaphragm. The O-Ring piston normally serves as a guide to maintain correct diaphragm alignment. In the event of diaphragm failure, the ball check is immediately closed by the escaping gas. This traps the gas beneath the piston which then becomes a substitute for the diaphragm to maintain operation.

The set point ( $P_c$ ) with the piston is approximately 70% of normal. This has two advantages. In the average installation it causes the 257S to open partly and thereby give a warning. In addition, it makes the wide open pressure ( $P_m$ ) approximately the same for sentry as for normal operation so there is no sacrifice in protection.

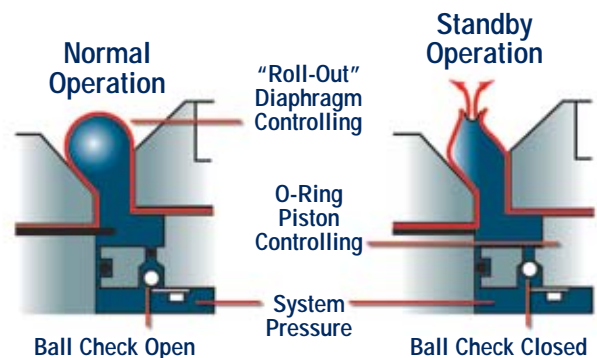

### Relief Pressure Adjustment Range

Relief Range	Color of Spring	Part Numbers
2 to 4 psi	Yellow	091-00-021-05
4 to 8 psi	Gray	091-00-021-04
8 to 12 psi	Blue	091-00-021-03
12 to 24 psi	Red	091-00-021-02
24 to 48 psi	Brown	091-00-021-01
48 to 65 psi	Black	091-00-021-00
65 to 100 psi	Black with a White inner spring	091-00-021-00 091-00-021-08

**Note:** Do not exceed maximum pressure of each spring.

### Discharge Capacity in 1000 SCFH of Natural Gas

(0.6 Specific Gravity – 14.65 psia -60°F)

Relief Blowing Pressure PSI Pi	2" Pipe Size	3" Pipe Size	4" Pipe Size
2	30	54	92
3	37	66	112
4	43	77	130
5	48	86	145
10	67	121	205
15	82	148	251
20	96	174	294
25	110	199	337
30	124	224	380
40	152	275	465
50	180	325	551
60	208	376	636
70	236	426	772
80	264	477	807
90	292	527	893
100	320	578	978
K	5600	10100	17100

For best results the capacity and sizing with stack piping should be calculated based upon the nomograms in Sensus Meter Systems Bulletin RDS-1452. Sizing the relief valve closer than +/- 12% could cause the actual maximum relief valve blowing pressure to exceed the calculated maximum due to spring rate, K factors, and part tolerances.

**Note:** Capacities are based on relief valve blowing full open to atmosphere.

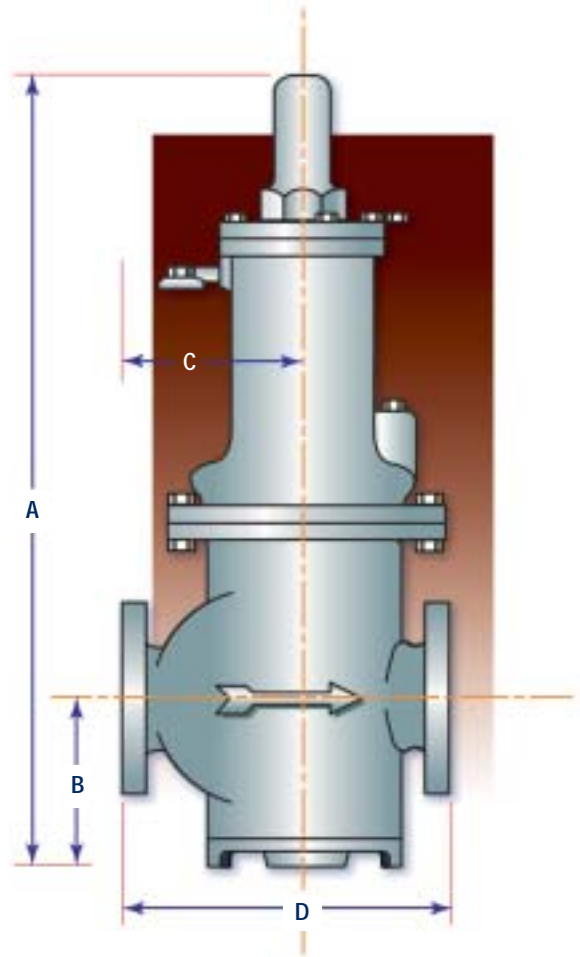

### Dimensions

Size	A	B	C	D
2"	24-1/4"	5-3/8"	5-5/8"	10"
3"	24-3/4"	5-3/8"	6-1/2"	11-3/4"
4"	26-1/2"	5-7/8"	6-3/4"	12-1/2"

### Weight (lbs.)

2"	3"	4"
95	105	125

# Model 250 Safety Relief Valves

## Large Capacity for

- Gas Distribution Systems
- Metering Sets
- Industrial Applications

## Heavy Duty Iron Construction

- Weatherproof
- Water Tight
- Indoors or Outdoors

## Materials of Construction

- Body, Diaphragm Clamping Spring Housing Weight Cover  
**Cast Iron (ASTM A 126 Class B)**
- Diaphragm Plate  
**Cast Iron**
- Diaphragm  
**Buna-N with Nylon Reinforcement**
- Valve Stem  
**Stainless Steel**
- Stem Bushing  
**Stainless Steel**
- Valve  
**Steel**
- Valve Disc  
**Buna-N**
- Valve Gland  
**Brass**
- Valve Wing  
**Brass**

## Angle Type Body

- Large exit area for high flow rate
- Allows valve removal without disturbing piping

## Vertical Piping

- Install as shown in vertical line
- Do not mount the 250-DW or 250-S relief valve in a horizontal position

## Deep Molded Diaphragm

- Provides maximum life after initial opening
- Diaphragm does not affect initial relief
- Without the diaphragm, valve travel is 15% to 20% of its diameter and discharge capacity is restricted.

## Drain Plug

- For moisture which may enter through discharge stack

## Test Plug on Inlet

## Stainless Steel Thrust Bearing

- Transmits loading force to reduce friction

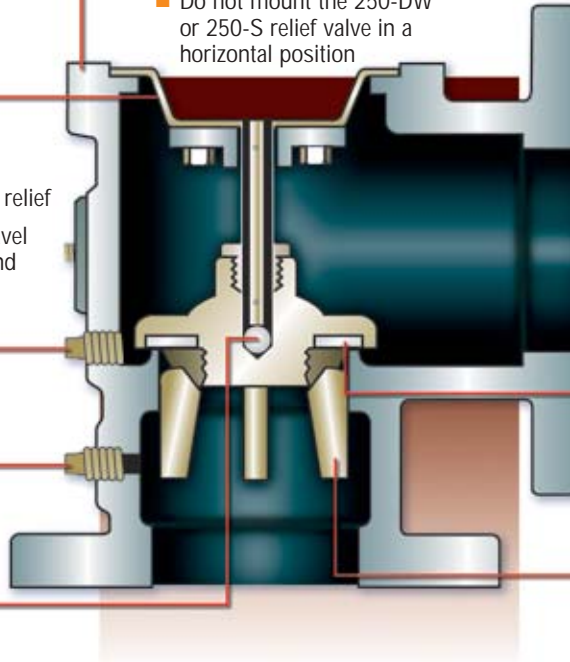

## Buna-N Soft Seat

- Provides tight seat and reset
- Retained for ease of replacement

## Wing Guides

- Permits high valve lift and flow capacity

## Model 250-DW

### Diaphragm Clamping Ring

- Models 250-S and 250-DW
- Permits removal of top cover without disturbing diaphragm assembly

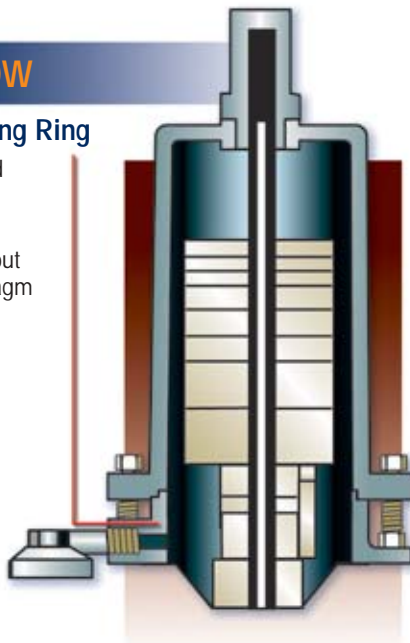

## Model 250-S

### Relief Valve Travel Stop Plate

### Stop Ring

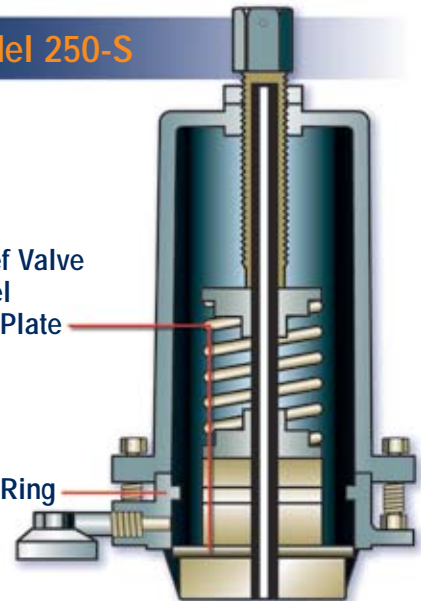

## Pipe Sizes 2" - 3" - 4"

Flanged ANSI 125 lb. FF  
2" Available with NPT Connections  
(Maximum working pressure 175 psi)

## Pressure Relief Range

8 oz to 70 psi



# Model 250-DW Deadweight Loaded



## Safety Relief Valves

Relief Pressure Adjustment Range	Size	Valve Diameter	Relief Pressure Adjustment Range	Minimum Relief Pressure Without Weights (oz)	Adjustment Weights		Maximum Number of Weights
					Size	Will Increase Relief Pressure (oz)	
2"	1-3/4"	1-3/4"	8 oz to 6 psi	15 (8 oz special)	3" x 1"	12	7 - 1"
					3" x 1/2"	6	
					3" x 1/4"	3	
3"	3"	3"	8 oz to 36 oz	8	3" x 1"	4	7 - 1"
					3" x 1/2"	2	
					3" x 1/4"	1	
3"	2-1/2"	2-1/2"	11 oz to 50 oz	11	3" x 1"	6	7 - 1"
					3" x 1/2"	3	
					3" x 1/4"	1.5	
4"	4"	4"	8 oz to 32 oz	8	3" x 1/2"	1	Use these weights first, immediately above diaphragm
					3" x 1/4"	0.5	
					3" x 1"	4	6 - 1" x 3-3/4"
					3" x 1/2"	2	
3" x 1/4"	1						

Discharge Capacity in SCFH of natural gas  (0.6 Specific Gravity 14.65 psia - 60°F)	Pc Initial Relief Pressure		Pm Maximum Blowing Pressure Pm = 1.25 Pc		Discharge Capacity allowing pressure increase from Pc to Pm				
	psi		oz		2"		3"		4"
	1" valve lift		1" valve lift		1-1/2" valve lift		1-1/2" valve lift		1-3/4" valve lift
	1-3/4" dia		3" dia		2-1/2" dia		4" dia		3" dia
0.50	8.0		10	9,250	23,600			51,000	
0.75	12.0		15	11,250	29,000			62,400	
1.00	16.0		20	13,150	33,500			72,100	
1.25	20.0		25	14,700	37,400			80,600	
1.50	24.0		30	16,100	41,000			88,300	
1.60	25.5	2.00	32	16,500	42,000			90,000	
1.75	28.0		35	17,400	44,300			95,400	
2.00	32.0		40	18,600	47,300			102,000	
2.25	36.0		45	19,700	50,200				75,300
2.50	40.0		50	20,800		44,100			79,300
2.75	44.0		55	21,800		46,200			83,200
3.00	48.0		60	22,800		48,300			86,900
4.00		5.00		26,300					
5.00		6.25		29,400					
6.00		7.50		32,200					

Discharge Capacity in SCFH of natural gas	Pc Initial Relief Pressure		Pm Maximum Blowing Pressure Pm = 1.5 Pc		Discharge Capacity allowing pressure increase from Pc to Pm				
	psi		oz		2"		3"		4"
	1" valve lift		1" valve lift		1-1/2" valve lift		1-1/2" valve lift		1-3/4" valve lift
	1-3/4" dia		3" dia		2-1/2" dia		4" dia		3" dia
0.50	8.0		12	10,100	32,400			55,800	
0.75	12.0		18	12,400	39,600			68,400	
1.00	16.0		24	14,400	45,800			79,000	
1.25	20.0		30	16,100	51,200			88,300	
1.30	21.0	2.00	32	16,600	53,000			91,000	
1.50	24.0		36	17,600	56,100			96,700	
1.75	28.0		42	19,000	60,600			104,500	
2.00	32.0		48	20,300	64,800			111,700	
2.25	36.0		54	21,600	68,700				82,500
2.50	40.0		60	22,700		56,200			86,900
2.75	44.0		66	23,900		59,000			91,200
3.00	48.0	4.50	72	24,800		61,600			95,200
4.00		6.00		28,800					
5.00		7.50		32,200					
6.00		9.00		35,200					

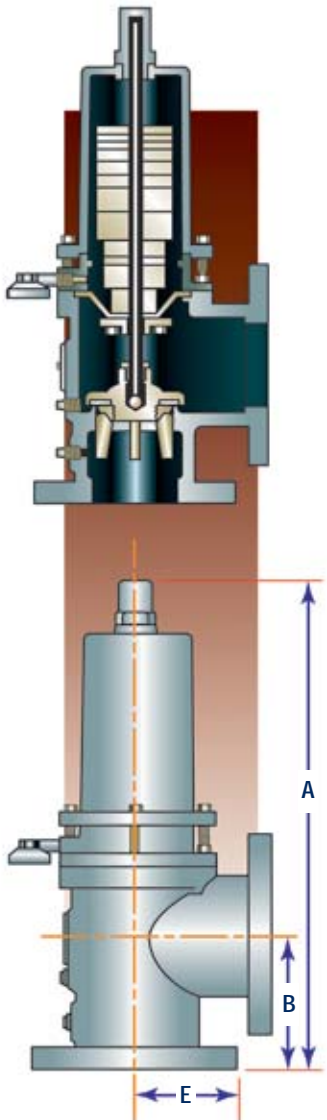

Dimensions				Weight Lbs.
Size	A	B	E	
2" NPT	16-3/4"	3-1/4"	3-1/4"	30
2" Flgd.	16-3/4"	4-1/4"	4-1/4"	40
3"	18-1/4"	5"	5"	65
4"	20"	6"	6"	110

## Model 250-S Spring Loaded

Dimensions				Weight Lbs.
Size	A	B	E	
2" NPT	19-1/2"	3-1/4"	3-1/4"	40
2" Flgd.		4-1/4"	4-1/4"	
3"	20-3/4"	5"	5"	65
4"	22-1/4"	6"	6"	

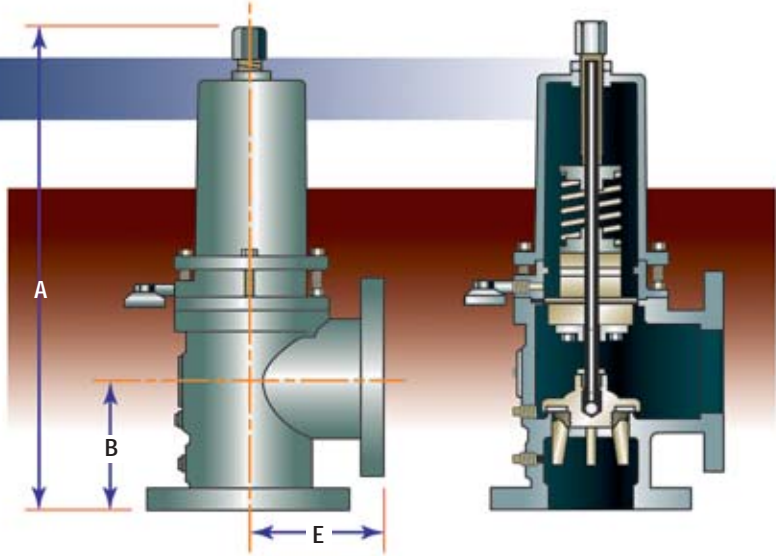

### Relief Pressure Adjustment Range

Color of Spring	Relief Pressure Adjustment Range, psi			
	2"		3"	
	1-3/4" dia.	3" dia.	4" dia.	3" dia.
Aluminum	2 – 10	1 – 4	1.00 – 2.25	
Green	10 – 16	4 – 6	2.25 – 3.50	
Yellow	16 – 26	6 – 10	3.50 – 5.50	
Gray	26 – 40	10 – 15	5.50 – 7.50	
Blue	30 – 70	15 – 30	7.50 – 16.00	15 – 30

### Discharge Capacity in SCFH of natural gas (0.6 Specific Gravity 14.65 psia – 60°F)

#### Allowing 50% Increase Above Initial Relief Pressure

Pc Initial Relief Pressure psi	Pm Maximum Blowing Pressure Pm = 1.5 Pc psi	Discharge Capacity allowing pressure increase from Pc to Pm			
		2"		4"	
		1" valve lift 1-3/4" dia	1" valve lift 3" dia	1-1/8" valve lift	
		4" dia	3" dia	4" dia	3" dia
3	4.5	18,700	49,500	68,400	
4	6.0	21,600	57,200	79,000	
5	7.5	24,100	64,000	88,300	
6	9.0	26,400	70,100	96,700	
7	10.5	28,500	75,700	104,500	
8	12.0	30,500	81,000	111,700	
9	13.5	32,400	85,900	118,500	
10	15.0	34,100	90,500	124,900	
12	18.0	37,600	99,700	137,700	
15	22.5	42,800	113,600	156,800	
20	30.0	51,500	136,700		141,500
25	37.5	60,300	159,800		165,400
30	45.0	69,000	182,900		189,300
40	60.0	86,400			

#### Allowing 100% Increase Above Initial Relief Pressure

Pc Initial Relief Pressure psi	Pm Maximum Blowing Pressure Pm = 2 Pc psi	Discharge Capacity allowing pressure increase from Pc to Pm			
		2"		4"	
		1" valve lift 1-3/4" dia	1" valve lift 3" dia	1-1/8" valve lift	
		4" dia	3" dia	4" dia	3" dia
3	6	28,800	73,300	101,400	
4	8	33,200	84,600	117,100	
5	10	37,100	94,600	130,900	
6	12	40,700	103,600	143,400	
7	14	44,000	112,000	155,000	
8	16	47,000	119,900	165,900	
9	18	50,200	128,800	176,900	
10	20	53,300	135,700	187,800	
12	24	59,500	151,400	209,600	
15	30	68,800	175,100	242,400	
20	40	84,300	216,600		222,900
25	50	99,300	254,000		263,900
30	60	115,300	293,500		304,800
40	80	146,200			

Sensus Metering Systems produces a broad product line of Gas Pressure Regulators which are widely used throughout the natural gas industry. These regulators are also suitable for non-corrosive industrial gas applications such as propane, butane, air, nitrogen, dry CO<sub>2</sub>, etc. For additional detailed information on a particular model, please request the indicated bulletin from the local Sensus sales office.

### Multi-Purpose Service Regulators

#### Model 043-B

Bulletin: R-1307  
3/8", 1/2", 3/4", 1" pipe size  
Inlet pressures to 125 psi  
Outlet pressures 3-1/2" w.c. to 2 psi  
Capacity to 2,200 CFH  
Available with 90° angle or straight-through body  
Internal relief valve standard

#### Model 143-B

Bulletin: R-1308  
3/4", 1" and 1-1/4" pipe size  
Inlet Pressures to 125 psi  
Outlet pressures 3-1/2" w.c. to 2 psi  
Capacity to 2,700 CFH  
Available with 90° angle or straight-through body  
Internal relief valve standard

#### Model 143-80

Bulletin: R-1301  
3/4", 1", 1-1/4" pipe size  
Inlet pressures to 125 psi  
Outlet pressures 3-1/2" w.c. to 6 psi  
Capacity to 2,400 CFH  
Available with or without internal relief valve

### Industrial Service Regulators

#### Models 243-8, 243-12, 243-8HP

Bulletin: R-1306  
1-1/4", 1-1/2" and 2" pipe size  
Inlet pressures to 125 psi  
Outlet Pressures 3-1/2" w.c. to 10 psi  
Capacity to 25,000 CFH  
Also available: internal relief valve, low pressure cut-off external control line, back pressure regulator, relief valve, vacuum regulator and vacuum breaker.

**Sensus Metering systems also produces  
Industrial and Combustion Regulators,  
High Pressure and High Capacity Regulators.  
Detailed information available on request.**

### Industrial Field Regulators

For intermediate to high pressure applications. Ideal on pipeline taps servicing plants and buildings. Appropriate for double stage reduction ahead of service regulators, and for high pressure burners and compressed air systems.

#### Model 046

Bulletin: R-1312  
3/4", 1" and 1-1/4" pipe size  
Inlet pressures to 1000 psi  
Outlet pressures 3 to 200 psi  
Capacity to 40,000 SCFH  
Internal relief valve also available

#### Model 141A

Bulletin: R-1311  
2" pipe size  
Inlet Pressures to 1500 psi  
Outlet Pressures 5 to 400 psi  
Capacity to 55,000 SCFH

### Pilot Loaded Regulators

For intermediate and high pressure applications requiring precise pressure reduction with minimal droop. Ideal for standard and high capacity flows on burners, driers, dehydrators and compressor lines. Appropriate for fixed factor billing.

#### Model 243-RPC

Bulletin: R-1343  
1-1/4", 1-1/2" and 2" pipe size  
Inlet pressures to 150 psi  
Outlet pressures 3-1/2" w.c. to 35 psi  
Capacity to 76,000 SCFH

#### Model 1200

Bulletin: R-1342  
Pipe Size: 2" (flanged)  
Inlet pressures to 1200 psi  
Outlet pressures 20 to 600 psi  
Capacity to 789,000 SCFH

#### Model 121-RPC

Bulletin: RDS-1328  
Pipe size: 1-1/2", 2" and 2-1/2"  
Inlet pressures to 60 psi  
Outlet pressures to 3-1/2" w.c. to 35 psi  
Capacity to 186,000 SCFH

#### Model 1100

Bulletin: R-1341  
Pipe size: 2" (screwed or flanged)  
Inlet pressures to 400 psi  
Outlet pressures 3" w.c. to 100 psi  
Capacity to 414,000 SCFH



## Safety Relief Valves

805 Liberty Boulevard  
DuBois, PA 15801  
814-371-8000  
F814-375-8460

**Representatives in all principal cities.  
Distributors throughout the world.**

---

## Authorized Distributor:

### Limited Warranty

Seller warrants the Goods to be free from defects in materials manufactured by Seller and in Seller's workmanship for a period of one (1) year after tender of delivery (the "Warranty Period"). THIS LIMITED WARRANTY (a) IS IN LIEU OF, AND SELLER DISCLAIMS AND EXCLUDES ALL OTHER WARRANTIES, STATUTORY, EXPRESS OR IMPLIED, INCLUDING, WITH LIMITATION, ANY WARRANTY OF MERCHANTABILITY OR FITNESS FOR A PARTICULAR PURPOSE, OR OF CONFORMITY TO MODELS OR SAMPLES; (b) does not apply to any Goods which have been (i) repaired, altered or improperly installed; (ii) subjected to improper use or storage, (iii) used or incorporated with other materials or equipment, after buyer or anyone using the Goods has, or reasonably should have, knowledge of any defect or nonconformance of the Goods; or (iv) manufactured, fabricated or assembled by anyone other than Seller, (c) shall not be effective unless buyer notifies Seller in writing of any purported defect or nonconformance with (thirty days) after Buyer discovers or should have reasonably discovered such purported defect or nonconformance; and (d) shall only extend to Buyer and not to any subsequent buyers or users of the Goods. Buyer shall provide Seller access to the Goods as to which Buyer claims a purported defect or nonconformance, upon request by Seller, buyer shall, at its own risk and expense, promptly return the Goods in question to Seller's Plant.