

461-S, 461-8S and 461-12S Regulators

Brochure

Introduction

The Sensus Models 461-S, 461-8S and 461-12S are balanced valve, spring type regulators designed for distribution and industrial applications where a single seat regulator is too small and the usual 2" balanced valve regulators are too large. They are made in 2" pipe sizes only and are used for:

- Inlet Pressures to 175 psi**
- Outlet Pressures of 0 to 10 psi**

Contoured body passages for reducing turbulence and large exit areas give them a broad capacity capability thus making them applicable to a wide variety of load handling requirements.

Their outstanding control characteristics are illustrated by the curves on Page 3. Capacities are provided on Page 4.

The 461-S and 461-12S are unusually dependable regulators. Their design is simple, the construction is sturdy. Servicing and adjustment are easy, response is fast. The overall operation is stable and sensitive, and they provide exceptionally precise regulation.

The 461-S, 461-8S and 461-12S are excellent regulators for general usage. They also make an excellent choice for such special applications as snap action on-off loads and monitoring service.

Maximum Inlet Pressure

Diaphragm Size I.D.	Diaphragm Case Material	Maximum Inlet Pressure*
12"	Cast Iron	100 psi
8½"	Cast Iron	175 psi
12"	Aluminum	100 psi
8"	Aluminum	175 psi

*The regulator should not be used for pressures exceeding the recommended maximum inlet.

Spring Ranges

Minimum	Outlet Pressure		Size (I.D.) and Case Material	Spring Colors†
		Maximum		
2" w.c.*		10" w.c.	12" Cast Iron	Aluminum
4" w.c.		16" w.c.	12" Cast Iron	Green
7" w.c.		29" w.c.	12" Cast Iron	Yellow
0.5 psi		1.75 psi	12" Cast Iron	Gray
1 psi		3.5 psi	12" Cast Iron	Blue
3½" w.c.		6½" w.c.	12" Aluminum	Red
5" w.c.		8½" w.c.	12" Aluminum	Blue
6" w.c.		14" w.c.	12" Aluminum	Green
12" w.c.		28" w.c.	12" Aluminum	Orange
1 psi		2 psi	12" Aluminum	Black
1.5 psi		3 psi	12" Aluminum	Cadmium
3 psi		6 psi	8½" Cast Iron	Blue
5 psi		10 psi	8½" Cast Iron	Red
1 psi		2 psi	8" Aluminum	Orange
2 psi		4.25 psi	8" Aluminum	Black
3 psi		6.5 psi	8" Aluminum	Cadmium
6 psi		10 psi	8" Aluminum	Cadmium (outer) White (inner)

For outlet pressures above 3 psi refer also to:

- Model 461-57S - a direct operated spring regulator for 100 psi maximum outlet (Bulletin R-1331).
- Model 1100 - a pilot operated regulator for 150 psi maximum outlet (Bulletin R-1341).

Maximum Pressure Differential and Maximum Inlet Pressure for Various Soft-Seated Valve Materials*

Valve Material	Maximum Pressure Differential	Maximum Inlet Pressure
Buna-N (black, 50 to 55 duro)	250 psi	575 psig
Polyurethane (red, 65 to 75 duro)	400 psi	720 psig
Polyurethane (tan, 85 to 95 duro)	600 psi	1200 psig

*The differential and inlet pressures given are only to be used as general guidelines. In all cases, pressures must always remain within the ranges specified in Sensus literature. For any given regulator, do not exceed the specified maximum pressures.

The maximum temperature for the above materials is 150°F.

Vitron valve material has a maximum temperature rating of 300°F and a maximum pressure differential of 250 psi.

Body Pressure Ratings

Regulator Body Type	Maximum Working Pressure of Body*
Screwed End	250 psi
Flanged ANSI 125 lb. FF	175 psi
Flanged ANSI 250 lb. RF	575 psi
Flanged ANSI 300 lb. RF	720 psi

*This only applies to the body. The regulator should not be used for inlet pressures that exceed the maximums specified in the Maximum Inlet Pressure table above.

Temperature Limits

The 461-S, 461-8S and 461-12S regulators may be used for flowing gas temperatures from -20° to 150°F.

Buried Service

The 461-S, 461-8S and 461-12S regulators are **not** recommended for buried service.

Construction Features

Regulator self contained – no exposed parts-top moisture sealed-safe for pits by extending vent line.

Flow contoured body – large gas exit area reduces turbulence, increased capacity.

Side inspection plates – O-ring sealed-for visual valve inspection or adjustment.

Balanced valve – permits higher inlet pressures – eliminates variation effect – gives greater capacity.

Soft seat valves – tight lock-up at zero flow. Molded discs resist blow out. Adjustment valve spacing. Renewable orifices – two interchangeable sizes.

Springs color coded – self-aligning adjustment – easily changed through gasketed top opening.

**Heavy Duty
Cast Iron
Diaphragm Case (shown)**
(Sizes 8½" and 12" I.D.)

**Lightweight Aluminum
Diaphragm Case**
(Sizes 8" and 12" I.D.)

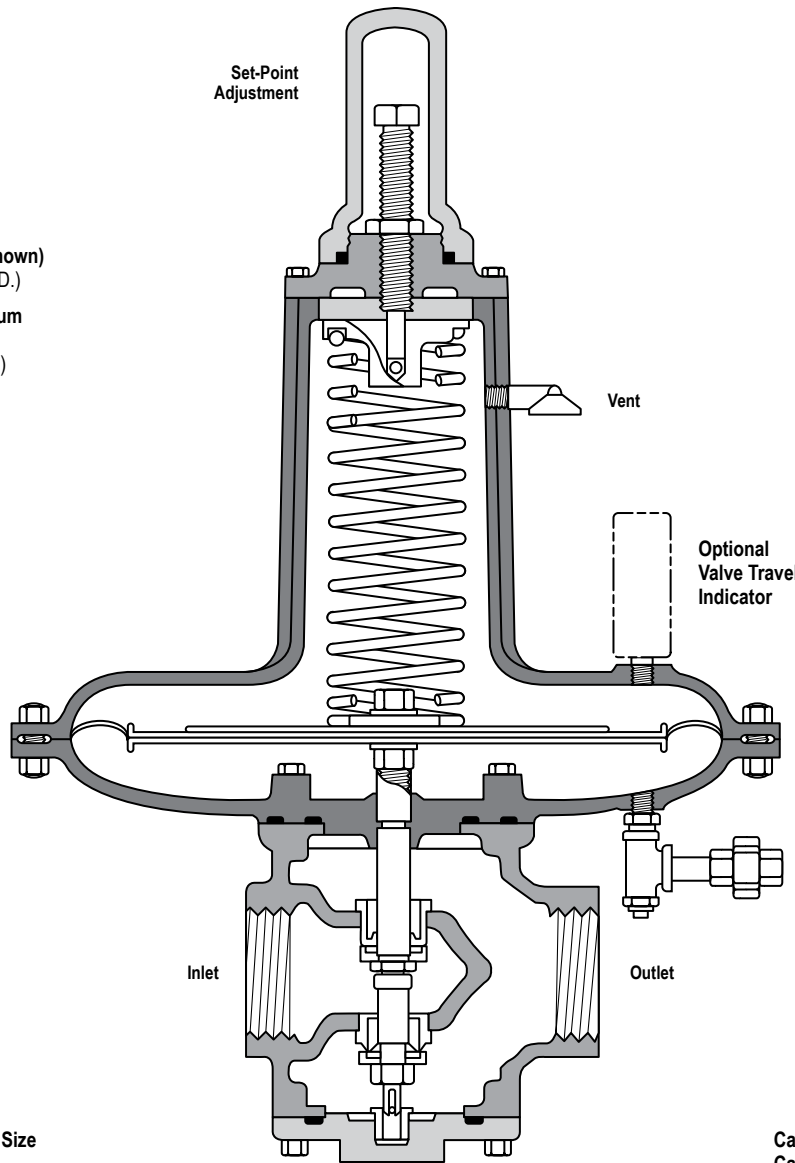

Control Line Connection
(Differs on Aluminum case
461-8S and 461-12S.
See bulletin RM-1330.)

**Balanced Valve Full Size
and Reduced Sizes**
(See Page 7)

**Cast Iron, Ductile Iron or
Cast Steel Body**
(See Pages 8 and 9)

461-S, 461-8S AND 461-12S GAS PRESSURE REGULATORS

GCD1330-005

Typical Performance Curves

Performance

These performance curves are typical for the Model 461-S. The outlet pressure for each chart was set under the stated conditions and was not further adjusted during changes in inlet pressure or flow. Settings in general were made at an inlet of 5 psi. Set-point to lock-up at zero flow requires a pressure increase of not more than 3" w.c.

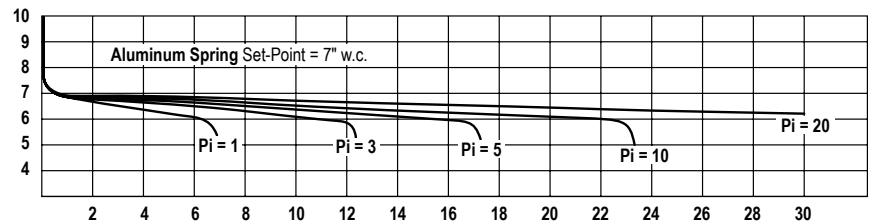
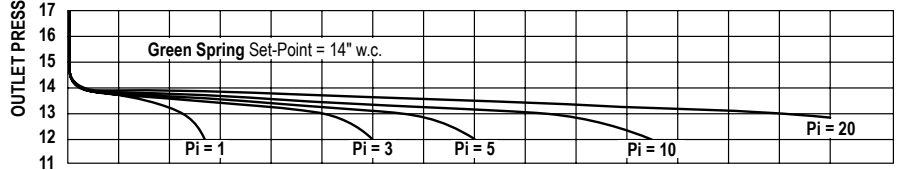
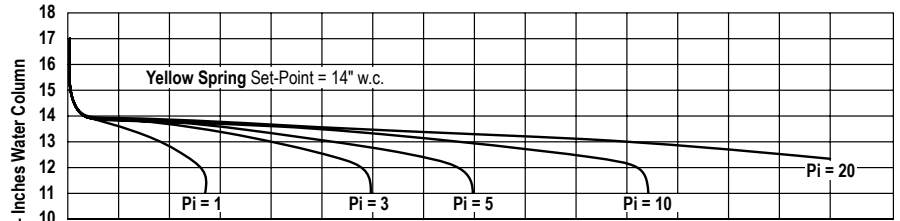
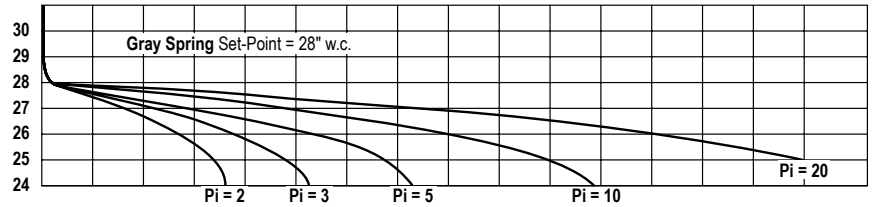
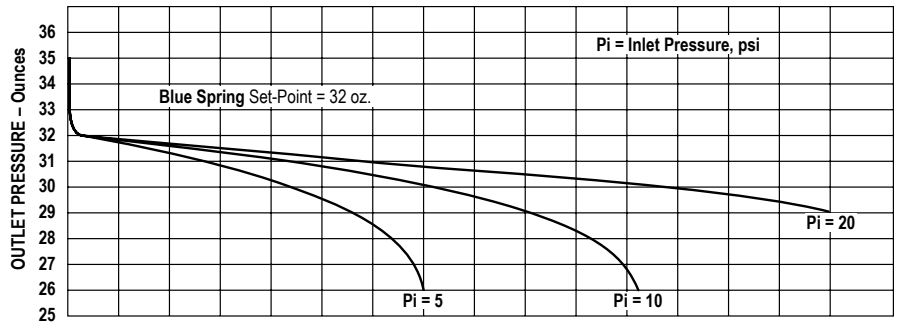

FLOW RATE - Thousand Cubic Feet Per Hour (0.6 Specific Gravity Gas 14.65 psi Absolute and 60°F).

Model 461-S, 461-8S and 461-12S Capacity Tables

Capacity in 100 SCFH of Natural Gas (0.6 Specific Gravity – 14.65 psia – 60°F)

Inlet Pressure psi	Outlet Pressure psi	Double Seat Balanced		Single Seat Balanced*	
		1" Valve	1/16" Valve	1" Valve	1/16" Valve
1/4	4" w.c.	2.5	1.25	—	—
	7" w.c.	3.8	1.9	—	—
1/2	4" w.c.	4.5	2.27	—	—
	7" w.c.	3.8	1.9	—	—
	1/2 psi	5.4	2.73	—	—
1	4" w.c.	7.0	3.5	—	—
	7" w.c.	6.6	3.3	—	—
	1/2 psi	5.4	2.73	—	—
2	4" w.c.	10.4	5.2	—	—
	7" w.c.	10.0	5.0	—	—
	1/2 psi	9.4	4.7	—	—
	1 psi	7.8	3.9	—	—
3	4" w.c.	12.8	6.4	—	—
	7" w.c.	12.6	6.3	—	—
	1/2 psi	12.2	6.1	—	—
	1 psi	11.0	5.5	7.1	3.5
	2 psi	8.0	4.0	5.2	2.6
4	4" w.c.	15.0	7.5	—	—
	7" w.c.	14.8	7.4	—	—
	1/2 psi	14.4	7.2	—	—
	1 psi	13.6	6.8	8.8	4.4
	2 psi	11.4	5.7	7.4	3.7
5	3 psi	8.4	4.2	5.4	2.7
	4" w.c.	16.8	8.4	—	—
	7" w.c.	16.6	8.3	—	—
	1/2 psi	16.4	8.2	—	—
	1 psi	15.6	7.8	10.1	5.0
	2 psi	14.0	7.0	9.1	4.5
6	3 psi	11.8	5.9	7.6	3.8
	4 psi	8.6	4.3	5.6	2.8
	7" w.c.	18.2	9.1	—	—
	1/2 psi	18.0	9.0	—	—
	1 psi	17.6	8.8	11.4	5.7
8	2 psi	16.2	8.1	10.5	5.2
	3 psi	14.4	7.2	9.3	4.3
	4 psi	12.2	6.1	7.9	3.9
	5 psi	8.8	4.4	5.7	2.8
	7" w.c.	21.2	10.6	—	—
10	1/2 psi	21.0	10.5	—	—
	1 psi	20.8	10.4	13.5	6.7
	2 psi	19.8	9.9	12.8	6.4
	3 psi	18.6	9.3	12.1	6.0
	4 psi	17.2	8.6	11.1	5.6
	5 psi	15.2	7.6	9.8	4.9
12	6 psi	12.8	6.4	8.3	4.1
	7" w.c.	23.8	11.9	—	—
	1/2 psi	23.6	11.8	—	—
	1 psi	23.4	11.7	15.2	7.6
	2 psi	23.0	11.5	14.9	7.4
	3 psi	22.2	11.1	14.4	7.2
12	4 psi	21.0	10.5	13.6	6.8
	6 psi	18.0	9.0	11.7	5.8
	8 psi	13.4	6.7	8.7	4.3
	7" w.c.	26.2	13.1	—	—
	1/2 psi	26.0	13.0	—	—
	1 psi	25.8	12.9	16.7	8.3
	2 psi	25.6	12.8	16.6	8.3
12	3 psi	25.2	12.6	16.3	8.2
	4 psi	24.4	12.2	15.8	7.9
	6 psi	22.2	11.1	14.4	7.2
	8 psi	19.0	9.5	12.3	6.1
10 psi	14.0	7.0	9.1	4.5	

Capacity in 100 SCFH of Natural Gas (0.6 Specific Gravity – 14.65 psia – 60°F) (Continued)

Inlet Pressure psi	Outlet Pressure psi	Double Seat Balanced		Single Seat Balanced*	
		1" Valve	1/16" Valve	1" Valve	1/16" Valve
15	1 psi & less	29.4	14.7	19.1	9.5
	2 psi	29.2	14.6	18.9	9.4
	3 psi	29.0	14.5	18.8	9.4
	4 psi	28.6	14.3	18.6	9.3
	6 psi	27.2	13.6	17.6	8.8
	8 psi	25.0	12.5	16.2	8.1
20	10 psi	22.2	11.1	14.4	7.2
	3 psi & less	34.6	17.3	22.5	11.2
	6 psi	34.0	17.0	22.1	11.0
	8 psi	32.8	16.4	21.3	10.6
25	10 psi	31.4	15.7	20.4	10.2
	6 psi & less	39.6	19.8	25.7	12.8
	8 psi	39.2	19.6	25.4	12.7
30	10 psi	38.4	19.2	24.9	12.4
		44.4	22.2	28.8	14.4
40		54.4	27.2	35.3	17.6
50		64.4	32.2	41.8	20.9
60		74.4	37.2	48.3	24.1
80	10 psi & less	94.2	47.1	61.2	30.6
100		114	57.2	74.3	37.1
125		139	69.6	90.4	45.2
150		164	82.0	106	53.3
175		189	94.8	123	61.6
"K" Factors Standard Valves		2000	1000	1300	650
"K" Factors For V-Port Valves, Multiply table by:		.750	N/A	.750	N/A

*The single seat balanced valve should not be used for outlet pressures below 1 psi.

Size each regulator on the basis of the **minimum expected inlet pressure** and the **maximum required outlet pressure**.

If greater capacity is required, refer to Model 441-S (Bulletin R-1350).

Expanded Outlet Line

These flow rates represent the amount of gas the regulator can actually pass at the given pressure reduction. This amount often exceeds the amount a 2" outlet line can take away, and the flow is restricted to the line capacity.

To take advantage of regulator capacity, make certain the outlet line has equal capacity, and increase the line size at the regulator outlet as necessary, to secure adequate capacity.

NOTE

The above performance data is based on normal testing at 70° flowing temperature. Changes in performance can occur at extreme low flowing temperatures.

Relief Valves and Back Pressure Valves

Use Model 461-SR for those applications which require a higher degree of accuracy and sensitivity than is possible with standard poppet type reliefs.

Essentially, it is a regulator arranged to provide inlet pressure control.

When operating as a relief valve, it limits inlet pressure to a set maximum. At pressures below this, it remains closed. If the pressure should attempt to exceed this, it opens and bleeds off the excess.

As a back pressure valve, it prevents gas from exiting from a system until the system pressure reaches the set-point. At set-point it begins to open and then regulates the discharge so as to hold the system at set-point.

Relief Pressure Range

3" w.c. to 10 psi (for range of each spring and diaphragm combination, see table, Page 1).

Installation

1. Install in line as shown with pressure connected to side marked INLET.
2. For gas, pipe outlet to safe discharge point.
3. Connect inlet line to 1/4" union.
4. By turning adjustment screw, set valve to open at desired pressure. Turning clockwise increases opening pressure. The 461-SR is the same as the 461-S except that inner valve is reversed, the body is turned around, and the control line is arranged for connection to the inlet sign (upstream).

Model 461-SR offers these advantages: (1) accurate setting and control at low relieving pressure because of large, sensitive diaphragm; (2) tight shutoff without leakage due to soft-seat valve construction; (3) large relieving capacity due to large size double valves.

Over-pressurization Protection

Protect the downstream piping system and the regulator's low pressure chambers against over-pressurization (due to possible regulator malfunction or failure) to achieve complete lockup.

The allowable outlet pressure is the lowest of the maximum pressures permitted by federal codes, state codes, Sensus Bulletin RDS-1498, or other applicable standards.

The method of protection can be a relief valve, monitor regulator, shutoff device, or similar mechanism.

Maximum Emergency Pressures

For complete Maximum Emergency Pressure information for Model 461 regulators, refer to Sensus Bulletin RDS-1498, Regulator Pressure Ratings. If the maximum outlet pressure is exceeded, the regulator must be removed from service and carefully inspected. Damaged or otherwise unsatisfactory parts must be replaced before returning the regulator to service.

Periodic Inspection: Regulators are pressure control devices with numerous moving parts subject to wear that are dependent upon particular operating conditions. To ensure continuous satisfactory operation, adhere to a periodic inspection schedule with the frequency of inspection determined by the severity of service and applicable laws and regulations. See Bulletin RM-1330 for field service instructions.

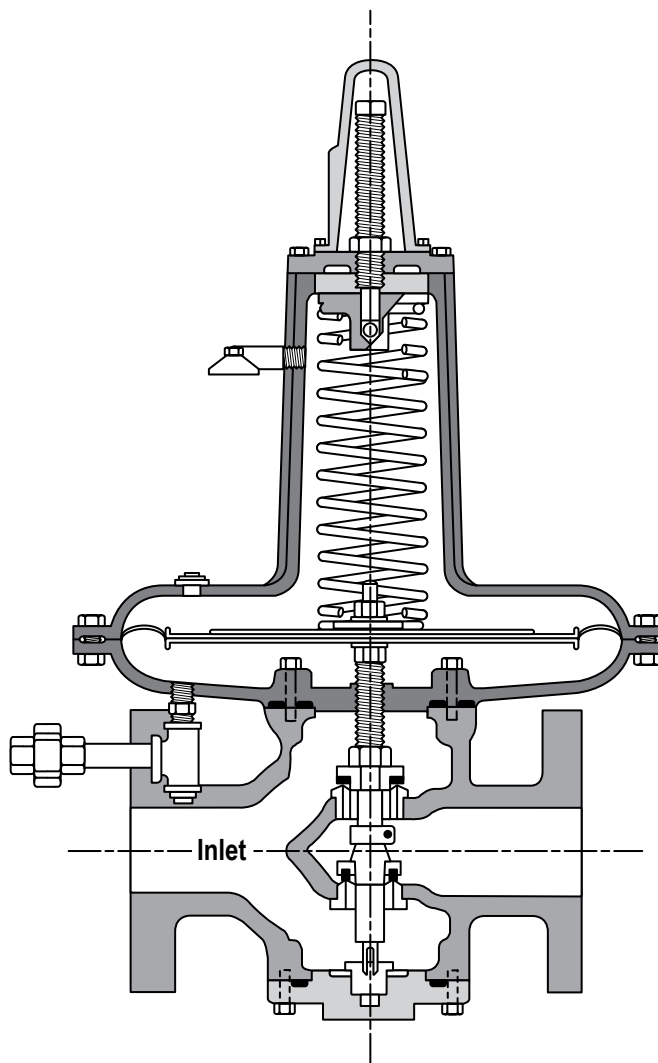

MODEL 461-SR

GCD1330-015

Materials of Construction

Diaphragm Housing, Spring Case (461-S)	Cast Iron (ASTM A126-71 Class B)
Diaphragm Housing, Spring Case (461-8S, 461-12S).....	Aluminum
Diaphragm Plates.....	Steel
Diaphragm.....	Buna-N with Nylon Fabric Reinforcement
Valve Stems.....	Brass or Stainless Steel
Removable Seats (Orifice)	Brass or Stainless Steel
Soft Seat Valve Material	Buna-N or Polyurethane pressure molded in holder.
Holder for Molded Valve	Steel
Valve retainer.....	Brass or Stainless Steel
Bodies	See table, on Page 9

Monitoring

The 461-S, 461-8S or 461-12S make an excellent monitor; a standby regulator installed in series which assumes control if a failure in the operating regulator permits the outlet pressure to exceed the set-point.

The fast rate of response enables it to take over quickly where necessary, and its outstanding performance means it will provide excellent standby regulation.

It can be located in either the upstream or the downstream position.

When a 461 is used to monitor a regulator with an identical inner valve (another 461, a Model 1100, etc.) the total maximum **capacity** through both can be figured at 70% of the capacity of one of them alone. This applies with the monitor located either upstream or downstream.

Capacities at Other Pressures

Capacity for pressures not listed in the table on Page 4 can be calculated with the following formulae:

Capacity for pressure reductions not listed in the table found in bulletin R-1332 can be calculated with the following formulae:

1. $Q = K\sqrt{P_0(P_1 - P_0)}$
2. $Q = \frac{K P_1}{2}$

Q = maximum capacity of the regulator (in SCFH of 0.6 specific gravity natural gas).

K = the “**K**” factor, the regulator constant (from the table)

P₁ = absolute inlet pressure (psia).

P₀ = absolute outlet pressure (psia).

Use formula 1, when $\frac{P_1}{P_0}$ is less than 1.894.

Use formula 2, when $\frac{P_1}{P_0}$ is greater than 1.894.

Metrication

Use the following for Metric Conversions:

std. meters³/hr. x 35.31 = std. ft.³/hr. (SCFH)
std. ft.³/hr. (SCFH) x 0.0283 = std. meters³/hr.

kilograms/centimeters²(kg/cm²) x 14.22 = psig
psig x 0.0703 = kilograms/centimeters²(kg/cm²)

kilopascals (kPa) x 0.145 = psig
psig x 6.90 = kilopascals (kPa)

bars x 14.50 = psig
psig x 0.69 = bars

millimeters water (mm H₂O) x .0394 = in. w.c.
in. w.c. x 25.4 = millimeters water (mm H₂O)

millimeters mercury (mm Hg) x 0.535 = in. w.c.
in. w.c. x 1.868 = millimeters mercury (mm Hg)

Other Gases

461-S, 461-8S and 461-12S regulators are mainly used on natural gas. However, they perform equally well on LP gas, nitrogen, dry CO₂, air and others.

Other Gases	Correction Factor
Air (Specific Gravity 1.0)	0.77
Propane (Specific Gravity 1.53)	0.63
1350 BTU Propane-Air Mix (1.20)	0.71
Nitrogen (Specific Gravity 0.97)	0.79
Dry Carbon Dioxide (Specific Gravity 1.52)	0.63

For other non-corrosive gases:
CORRECTION FACTOR = $\sqrt{\frac{0.60}{\text{Specific gravity of the gas}}}$

For use with gases not listed above, please contact your Sensus representative or Industrial Distributor for recommendations.

How to Order

1. 2" Model 461-S, 461-12S or 461-8S.
2. Body Type (see table, on Page 9).
3. Outlet Pressure and Spring (see table, Page 1).
4. Inlet Pressure (also, minimum and maximum inlet pressures, if available).
5. Capacity required (SCFH).
6. Type of Gas (natural gas, propane, etc.).
7. Trim (brass or stainless steel).
8. Valve size (1" or 1¹/₁₆").
9. Double seat or single seat (see Page 7) – if not specified, double seat will be furnished.

To Order Parts, Specify:

1. Pipe size and model number of regulator.
2. Serial number of regulator (if available) or other identifying information.
3. Part number and name of part.
4. Quantity.
5. For orifices and valve parts, specify size of valve (1" or 1¹/₁₆") and trim (brass or stainless steel).
6. For diaphragm, diaphragm plates, or upper or lower covers, specify material and size (12" Al., 8" Al., 12" CI or 8¹/₂" CI).
7. For springs, specify color and part number.
Part numbers and names can be found in Bulletin RM-1330.

Fully Interchangeable Valve Assemblies

Valve assemblies can be interchanged with the regulator in place in the line.

CAUTION

Turn gas on slowly. If an outlet stop valve is used, it should be opened first. Do not overload the diaphragm with a sudden surge of inlet pressure. Monitor the outlet pressure during start-up to prevent an outlet pressure overload. REFER TO RM-1330 FOR MORE DETAILED START-UP PROCEDURES.

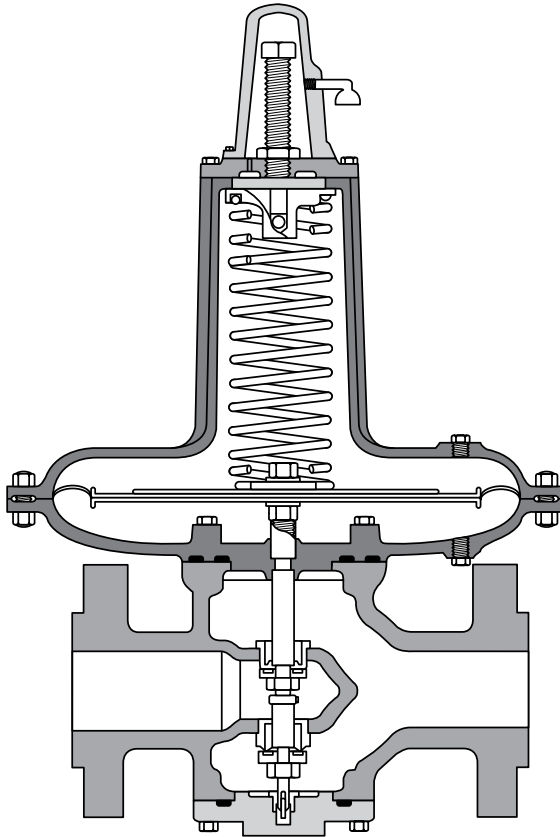

GCD1330-020

MODEL 461-S WITH DOUBLE SEAT BALANCED VALVE

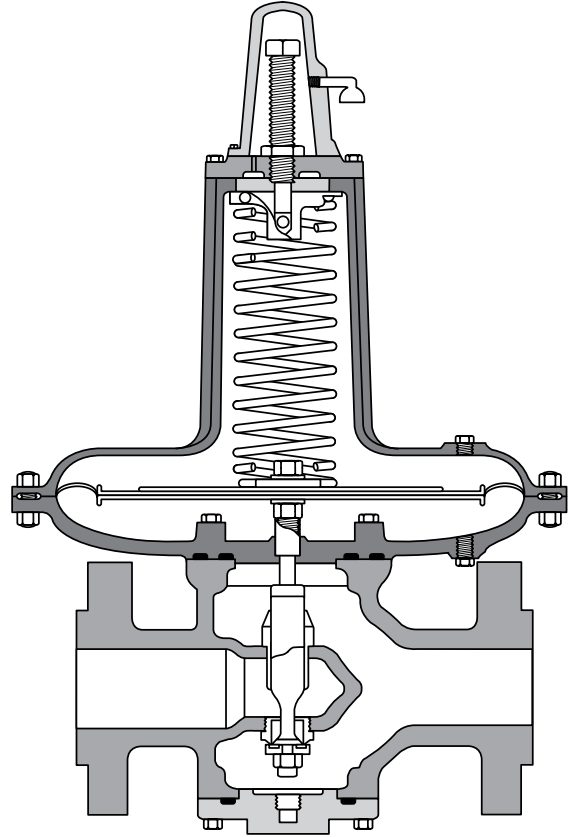

GCD1330-025

MODEL 461-S WITH SINGLE SEAT BALANCED VALVE

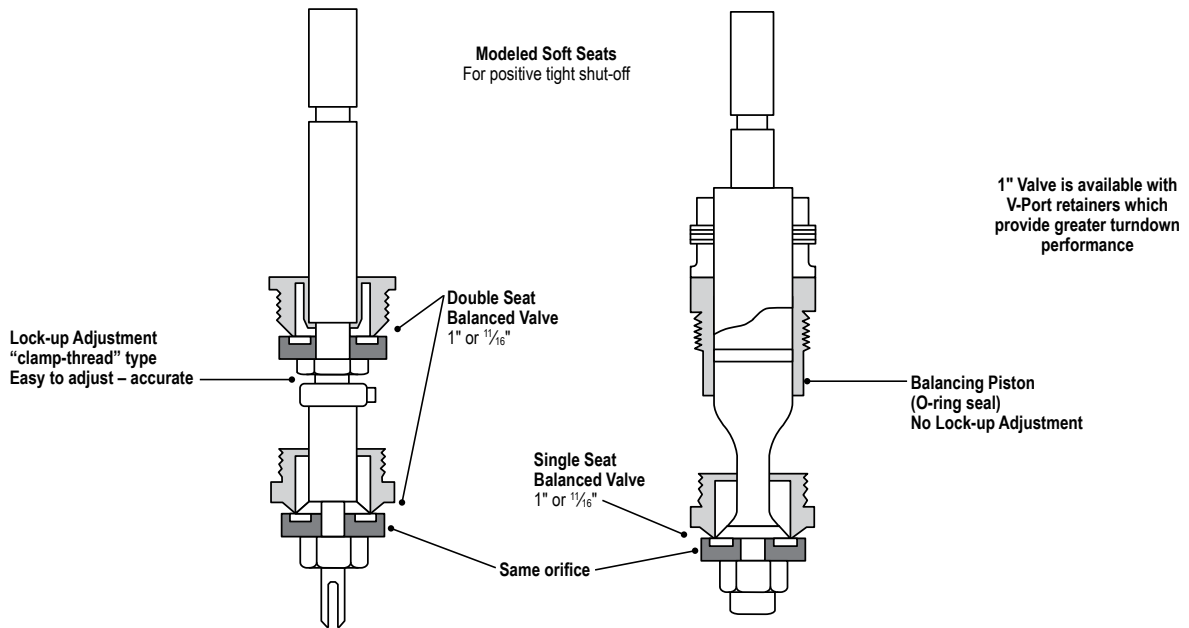

GCD1330-030A

GCD1330-030B

Other 461 Models for Distribution Systems and Industrials

CAUTION
 It is the user's responsibility to ensure all regulator vents and/or vent lines exhaust to a nonhazardous location away from any potential sources of ignition. REFER TO SENSUS BULLETIN RM-1330 FOR MORE DETAILED INFORMATION.

2" Model 461-57S
 "Roll-Out" Diaphragm Regulator
 Outlets of 3 to 100 psi
 See Bulletin R-1331

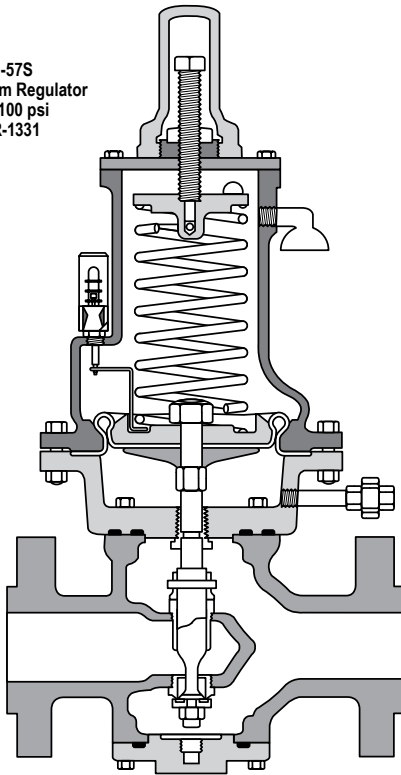

GCD1330-035

2" Model 100
 Pilot Operated Regulator
 See Bulletin R-1341

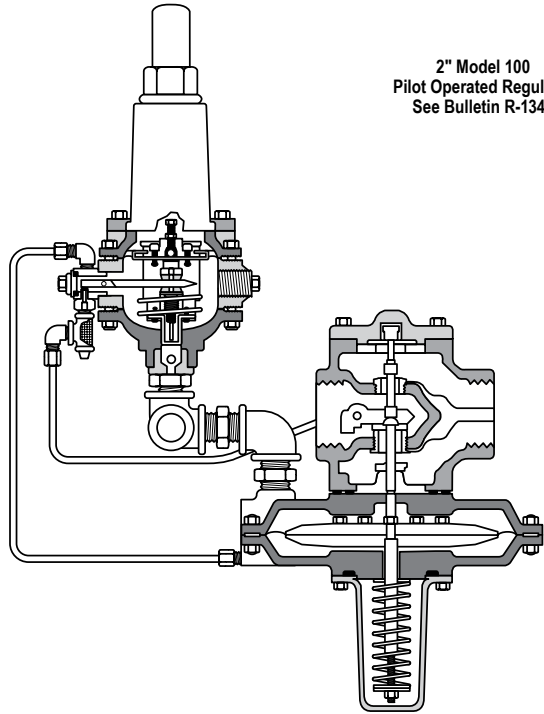

GCD1330-040

2" Model 461-X57
 High Pressure "Roll-Out"
 Diaphragm Regulator
 Outlets of 75 to 250 psi
 See Bulletin R-1332

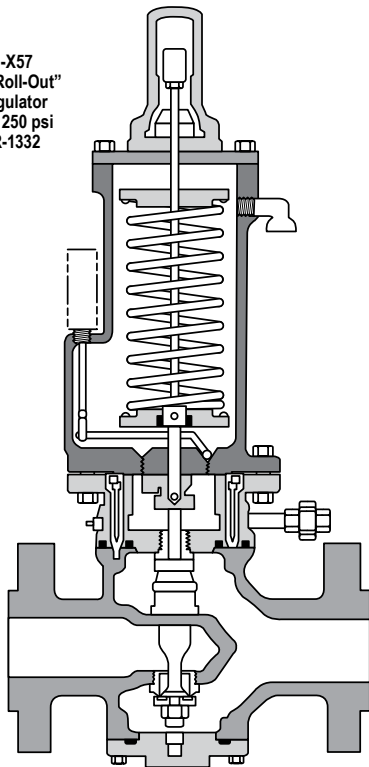

GCD1330-040

2" Model 1200
 All steel construction
 Outlets to 600 psi
 See Bulletin R-1342

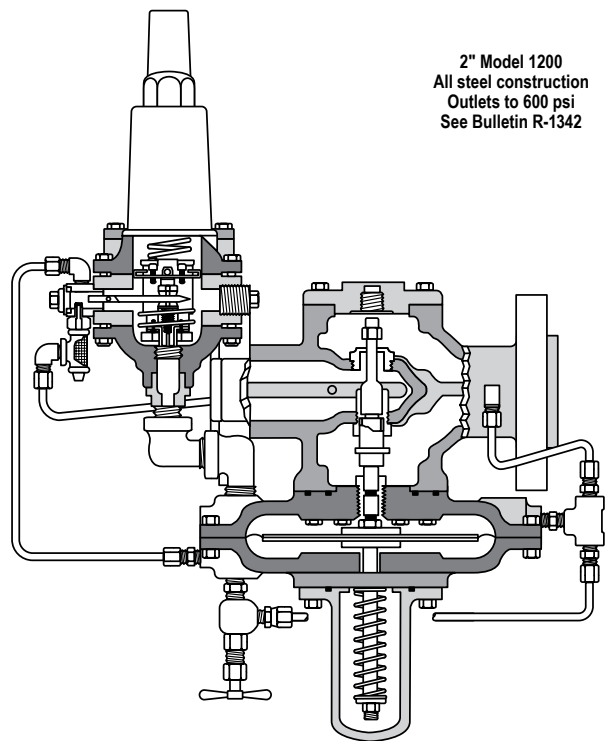

GCD1330-045

Dimensions

Model 461-S

Regulator Body Type	A	B	C	D (12")	D (8½")	Shipping Weight Lbs.	Body Material
Screwed End	6½"	—	19½"	14¼"	11"	75	Cast Iron (ASTM A126-71 class B)
Flanged 125 lbs.	10"	5¼"	19½"	14¼"	11"	80	Cast Iron (ASTM A126-71 class B)
Flanged 250 lbs.	10½"	5½"	19½"	14¼"	11"	85	Ductile Iron (ASTM A395-71 gr 60-40-18)
Flanged 300 lbs.	10½"	5½"	19½"	14¼"	11"	90	Cast Steel (ASTM A216-70a gr WCB)

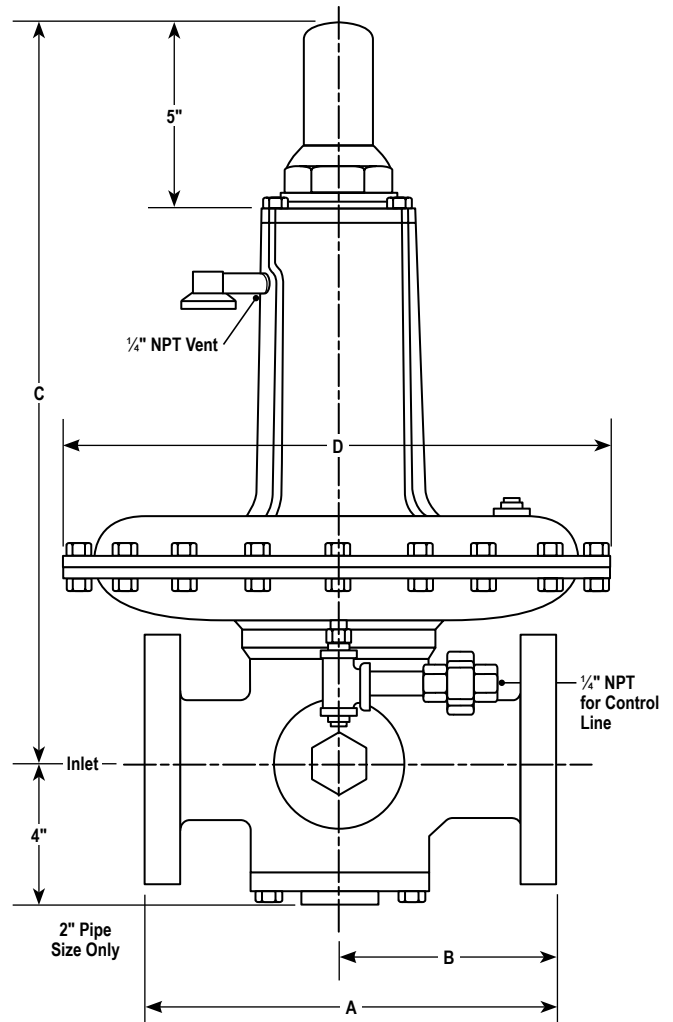

GCD1330-050

MODEL 461-S

Model 461-8S

Regulator Body Type	A	B	C	D (12")	Shipping Weight Lbs.	Body Material
Screwed End	6½"	—	—	10¾"	75	Cast Iron (ASTM A126-71 class B)
Flanged 125 lbs.	10"	5¼"	18¾"	10¾"	80	Cast Iron (ASTM A126-71 class B)
Flanged 250 lbs.	10½"	5½"	18¾"	10¾"	85	Ductile Iron (ASTM A395-71 gr 60-40-18)
Flanged 300 lbs.	10½"	5½"	18¾"	10¾"	90	Cast Steel (ASTM A216-70a gr WCB)

Model 461-12S

Regulator Body Type	A	B	C	D (12")	Shipping Weight Lbs.	Body Material
Screwed End	6½"	—	—	14"	75	Cast Iron (ASTM A126-71 class B)
Flanged 125 lbs.	10"	5¼"	13¾"	14"	80	Cast Iron (ASTM A126-71 class B)
Flanged 250 lbs.	10½"	5½"	13¾"	14"	85	Ductile Iron (ASTM A395-71 gr 60-40-18)
Flanged 300 lbs.	10½"	5½"	13¾"	14"	90	Cast Steel (ASTM A216-70a gr WCB)

Authorized Distributor:

All products purchased and services performed are subject to Sensus terms of sale, available at either: <http://na.sensus.com/TC/TermsConditions.pdf> or 1-800-METER-IT. Sensus reserves the right to modify these terms and conditions in its own discretion without notice to the customer.

This document is for informational purposes only, and SENSUS MAKES NO EXPRESS WARRANTIES IN THIS DOCUMENT. FURTHERMORE, THERE ARE NO IMPLIED WARRANTIES, INCLUDING WITHOUT LIMITATION, WARRANTIES AS TO FITNESS FOR A PARTICULAR PURPOSE AND MERCHANTABILITY. ANY USE OF THE PRODUCTS THAT IS NOT SPECIFICALLY PERMITTED HEREIN IS PROHIBITED.