

2" Large Single Port

Type A Flangeless
CL 150 – 600



2" Large Single Port Type A Flangeless Flowgrid® Valve with Series 20 Pilot

OVERPRESSURE PROTECTION

The Flowgrid® Valve is bi-directional and has a full ANSI rating on both the inlet and outlet. Overpressure protection is required only if the pressure can exceed the flange or body rating.

The pilots, like most regulators, may have an outlet pressure rating lower than the inlet pressure rating. If this is the case then some external form of overpressure protection must be provided for the pilot.

Anytime the Flowgrid® valve or pilot system is exposed to pressure in excess of its rating it should be inspected for damage.

The 2" Single Port Type A Flangeless Flowgrid® Valve is an economical and easy to maintain top entry pilot operated valve for both gas and liquid operations. This space saving valve has a face to face dimension of only 3.03" for the 150/300 CL valve and 3.41" for the 600 CL valve. These dimensions are the same as the American Axial Flow™ regulator, making the top-entry Flowgrid® Valve an ideal replacement.

SPECIFICATIONS

Size	2"
Body Style	Large Single Port (2")
End Connections	2" CL150, 300, 600 Flangeless
Temperature	Working -20°F to 150°F Emergency -40°F to 175°F
Max. Operating Differential	800 psi
Max. Emergency Differential	1000 psi
Min. Differential	Refer to graph on page 2
Cracking Differential	Refer to graph on page 2
Max. Inlet Pressure	1480 psig*
Outlet Pressure Range	Limited By Pilot
Flow Direction	Bi-Directional**
Body Taps	Two 1/4" - 18NPT

* Limited by pilot or flange rating

** Reverse flow by changing pilot connections and reversing spring case

MATERIALS OF CONSTRUCTION

Body & Spring Case	ASTM A 216 GR WCB Carbon Steel
Throttle Plate	17 - 4PH Stainless Steel or A515 Carbon Steel with ENC Coating
Diaphragm	Nitrile/Nylon* or Viton/Nylon
O-Ring & Seals	Nitrile, Optional (Viton)
Bolting	ASTM A 193 GR B-7 or Equal
Spring	301 Stainless Steel

*Refer to diaphragm selection chart on page 2.

STOCK NUMBERS

2" Large Single Port Type A Flangeless Valve	Stock #	Weight
150# Flangeless	FG-100	28 lbs.
300# Flangeless	FG-101	28 lbs.
600# Flangeless	FG-102	28 lbs.

DIMENSIONS

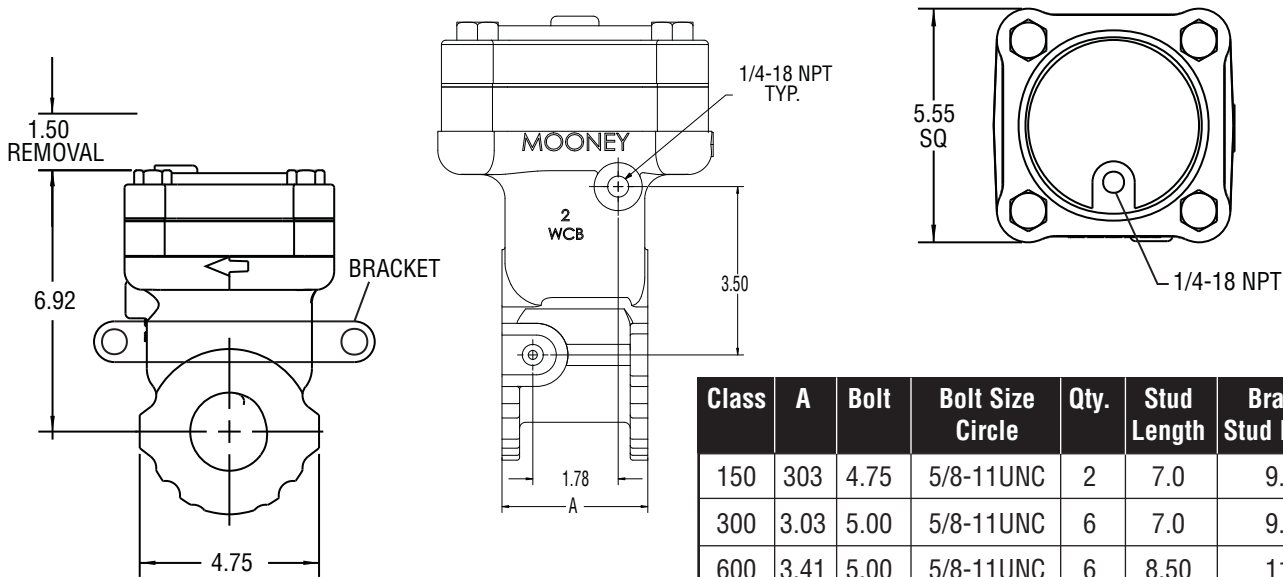

Class	A	Bolt	Bolt Size Circle	Qty.	Stud Length	Bracket Stud Length	Qty.
150	303	4.75	5/8-11UNC	2	7.0	9.50	2
300	3.03	5.00	5/8-11UNC	6	7.0	9.50	2
600	3.41	5.00	5/8-11UNC	6	8.50	11.0	2

Stud Material: A193 Grade B7 **Nut Material:** A194 Grade 2H

FLOW COEFFICIENTS AND CONSTANTS

2" Large Single Port Type A Flangeless Valve				Swage Factor	
Percent Capacity	Cv	C1	Cg	1.5:1	2:1
100%	40	35	1400	0.98	0.96
75%	33	33	1083	0.98	0.97
50%	27	30	824	0.99	0.98
35%	20	30	590	1.00	1.00

NOTE: Allow a 5% factor of safety when calculating relief capacity

MINIMUM PRESSURE DIFFERENTIAL VS. CAPACITY

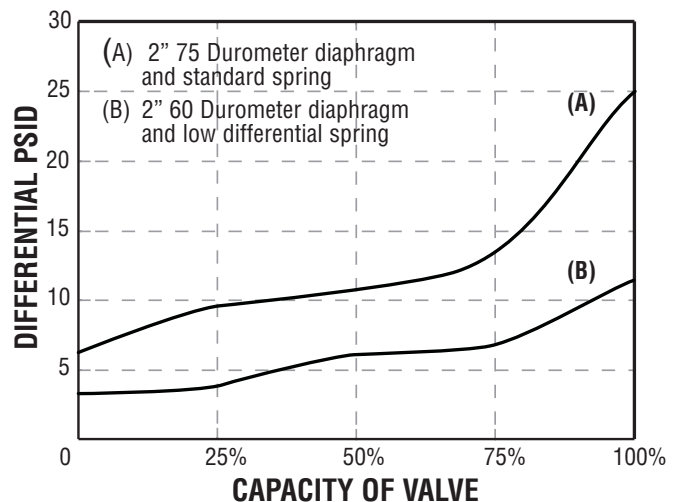

DIAPHRAGM SELECTION

Compound	Temp. Range (Degrees F)	Maximum Differential	Characteristics	Recommended Applications
75 Duro	-20 to 150	1000 psid	Best All Around Material	60 psid to Max. Differential
60 Duro	-25 to 150	300 psid	Best Shutoff at Low Differential Pressure	Low Differential (100 psid or less) or Low Temperature
80 Duro High ACN	-5 to 175	1000 psid	Higher Abrasion and Swelling Resistance	High Differential (400 psid or higher) or Abrasive Conditions with Distillates
80 Duro Low ACN	-20 to 150	1000 psid	Higher Abrasion Resistance and Low Temperature Flexibility	High Differential (400 psid or higher) or Abrasive Conditions at Low Temperatures

**Mooney
Dresser, Inc.**
2822 S. 1030 W.
Salt Lake City, Utah 84119
Phone: 801.487.2225 Fax: 801.487.2587
www.mooneycontrols.com



www.dresser.com