

Series 20 & 20S Pilot

The Series 20 & 20S Flowgrid® Pilot is a reversible pressure control regulator designed primarily for use as a control pilot with unloading type pilot systems for pressure reducing (PRV) backpressure (BPV or Relief), and differential pressure (DPV) applications. The Series 20 Pilot is designed for both liquid and gas applications. The unique cartridge design permits quick disassembly and allows the control action to be reversed simply by inverting the plug/stem assembly in the cartridge. The pilot is available in both brass (Series 20) and 304 stainless steel (Series 20S).

Specifications

Body Style	Pressure Reducing (PRV) & Back Pressure (BPV)	
Orifice Size	0.15 Inches (Standard) 0.17 Inches (Optional)	
Connections	1/4" NPTF	
Temperature Nitrile Diaphragm & O-rings	Working -20°F to 150°F Emergency -40°F to 200°F	
Temperature Viton Diaphragm & O-rings	30° F to 200°F	
Maximum Inlet Pressure	1500 psig	
Maximum Loading Pressure	1500 psig	
Maximum Outlet Pressure	1500 psig	
Maximum Emergency Sensing Pressure	1000 psig	
Maximum Spring Housing Pressure	1000 psig	
Set Pressure Range	3-12 psig 10-40 psig 25-90 psig	60-200 psig 100-260 psig 200-450 psig

* Anytime the Flowgrid® Pilot or Valve is exposed to pressures in excess of its rating it should be inspected for damage.

Flow Coefficients and Constants

Series 20/20S/20H/20HS Pilots			
	C_1	MAX C_g	MAX C_v
0.15 Orifice (standard)	38	9.58	0.25
0.17 Orifice (optional)	38	11.18	0.29

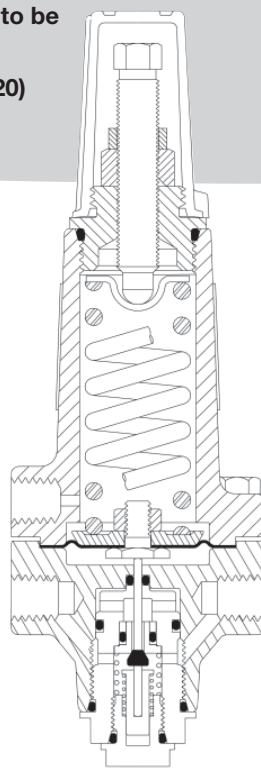

Sectional View



Series 20S Flowgrid® Pilot

Materials of Construction

Body & Spring Housing	Forged Brass or 304 Stainless Steel
Body Insert & Closing Cap	Brass or 304 Stainless Steel
Orifice	304 Stainless Steel or Delrin
Plug & Stem	Nitrile/304 Stainless Steel Viton/304 Stainless Steel 304 Stainless Steel
Diaphragm	Nitrile/Nylon or Viton/Nylon
O-rings	Nitrile or Viton

Dimensions

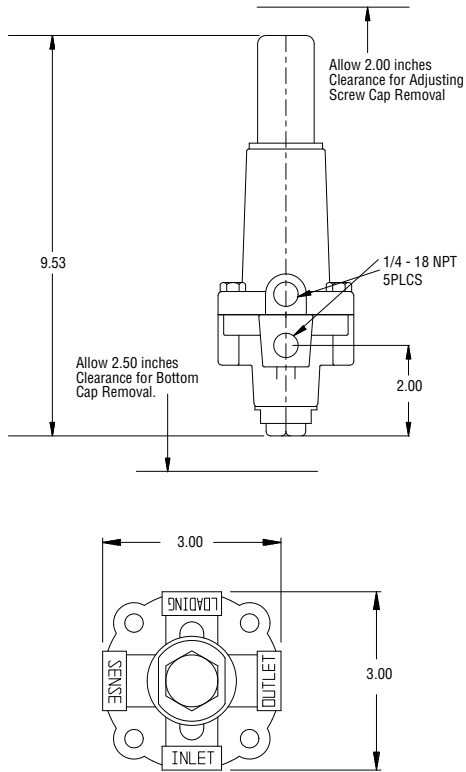

Trim Options

All Series 20 Pilots			
Internal Trim	Std. Construction	Option 1	Option 2
Orifice	304 Stainless	304 Stainless	Delrin
Plug/Stem	Nitrile/304 SSt	Viton/304 SSt	304 Stainless
Diaphragm	Nitrile/Nylon	Viton/Nylon	Nitrile/Nylon
O-ring	Nitrile	Viton	Nitrile

Stock Numbers

Series 20 Pilot (Brass)	Spring Color	PRV Stock	BPV Stock	Weight
3-12 psi	Red	FP-57	FP-58	6 lbs
10-40	Cadmium	FP-6	FP-16	6 lbs
25-90	Blue	FP-7	FP-17	6 lbs
60-200	Purple	FP-8	FP-18	6 lbs
100-260	Black	FP-9	FP-19	6 lbs
200-450	Green	FP-10	FP-20	6 lbs

Series 20S Pilot (Stainless)	Spring Color	PRV Stock	BPV Stock	Weight
3-12 psi	Red	FP-59	FP-60	6 lbs
10-40	Cadmium	FP-62	FP-36	6 lbs
25-90	Blue	FP-27	FP-37	6 lbs
60-200	Purple	FP-28	FP-38	6 lbs
100-260	Black	FP-29	FP-39	6 lbs
200-450	Green	FP-30	FP-40	6 lbs

Pilot Performance

Series 20 Pilot		Pressure Reducing Mode Restrictor Set at 4			Back Pressure Mode Restrictor Set at 4	
Spring Range	Color	Lock-up (psi)	Drop (psi) @ Max. Capacity ¹	Boost @ Constant Flow (psi) ³	Build up (psi) for Max. Capacity ²	Lock-up (psi)
3-12 ²	Red	1.0	0.3	0.7	²	²
10-40 ²	Cadmium	1.0	0.3	0.7	+0.50	-1.0
25-90	Blue	2.0	0.6	0.7	+0.50	-1.0
60-90	Purple	2.0	1.30	0.7	+1.0	-1.0
100-200	Black	5.0	2.00	0.7	+1.3	-1.5
200-450	Green	10.0	4.00	0.7	+5.0 ⁴	-2.0

- Inlet Pressure (P_1).
- Minimum set point for Flowgrid® Valve and Pilot when used as a Relief Valve (BPV) is 15 psig or the minimum differential whichever is greater.
- Per 100 psi decrease in inlet pressure (P_1).
- SST/Delrin trim required.

Pressure Reducing (PRV) Mode

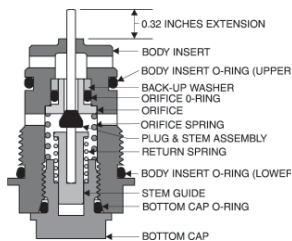

Back Pressure (BPV) Mode

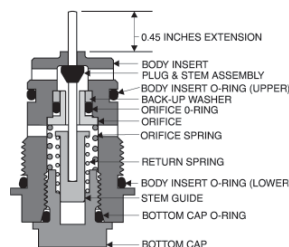

Cartridge Sectional View

* The difference between PRV and BPV Modes is that the Pilot Stem is inverted and the control action is reversed.

Dresser, Inc.

2822 S. 1030 W.
Salt Lake City, Utah 84119
Phone: 801.487.2225 Fax: 801.487.2587
www.dresser.com/mooney

